

SPECIFICATION OF ROBOT

MC004NFE70
(Air tool specification)

1st Edition : Nov.27.2013

KAWASAKI HEAVY INDUSTRIES LTD.
ROBOT DIV.

Doc, No:90101-2228DEA

[1] Robot Arm

1. Model	MC004N-B		
2. Name	MC004N		
3. Type	Articulated robot		
4. Degree of freedom	6 axes		
5. Axis specification	Operating axis	Max. operating range	Max. speed
	Arm rotation (JT1)	+180° ~ -180°	200° /s
	Arm out-in (JT2)	+135° ~ -95°	180° /s
	Arm up-down (JT3)	+60° ~ -155°	225° /s
	Wrist swivel (JT4)	+270° ~ -270°	700° /s
	Wrist bend (JT5)	+120° ~ -120°	500° /s
	Wrist twist (JT6)	+270° ~ -270°	350° /s
6. Repeatability	±0.05 mm (at the tool mounting surface)		
7 Max. payload	4 kg		
8 Max. speed	5000 mm/s (at the center of tool mounting surface)		
9. Load capacity of wrist		Max. torque	Moment of inertia *
	JT4	8.5 N·m	0.20 kg·m ²
	JT5	8.5 N·m	0.20 kg·m ²
	JT6	4.0 N·m	0.10 kg·m ²
	Note * Each value in this table shows allowable moment of inertia of JT4/JT5/JT6 when max. allowed torque is applied to each axis. If more detailed data is required for your application, please contact Kawasaki.		
10. Driving motor	Brushless AC Servomotor		
11. Working range	See attached drawing		
12. Mass	25 kg (without options)		
13. Color	White 12-MTJ-500938 (Epoxy paint)		
14. Installation	Floor or Ceiling mounting		
15. Environment cond.	(Temperature) 10 ~ 35 °C, (Humidity) 35 ~ 85 %, no dew, nor frost allowed		
16. Cleanliness	ISO Class 5		
17. Built-in utilities	Pneumatic piping (φ 4 x 2lines)		
18. Degree of protection	Wrist : IP67 Arm : IP65		
19. Options	Sensor harness (8 circuits), wired inside robot arm		
	Double solenoid/ Single solenoid valves (2 units max.)		
20. Others	Consult Kawasaki about maintenance parts and spare parts.		

[2] Controller		
1. Model	E70/E71	
2. Enclosure	Enclosed structure / Indirect cooling system	
3. Dimensions	See attached drawing	
4. Number of controlled axes	6 axes Max.8 axes(two built-in additional amplifier, option)	
5. Servo control and drive system	Full Digital Servo System	
6. Type of control	Teach mode	Joint, Base, Tool, Fixed Tool (option) operation mode
	Repeat mode	PTP, CP control mode Joint, Linear, Circular (option) interpolation
7. Teaching method	Teaching or AS language programming	
8. Memory capacity	8 MB	
9. External operation signals	External Motor Power Off, External Hold, etc.	
10. General purpose signals	Input signals	32 channels (Includes dedicated signals)
	Output signals	32 channels (Includes dedicated signals)
11. Operation panel	FastCheck/Teach/Repeat SW, Emergency Stop SW, Control power lamp	
12. Cable length	Power/Signal cable	10 m
	Teach Pendant cable	10 m
13. Mass	See attached drawing	
14. Power requirement	AC200 V - AC240 V±10%, 50/60 Hz, 1 phase, Max 1.5 kVA(E70), Max 3 kVA(E71)	
15. Ground	Less than 100 Ω (robot dedicated ground) Leakage current: max. 100 mA	
16. Ambient temperature	0 - 45 °C (Horizontal mount), 0 - 40°C (Vertical mount)	
17. Relative humidity	35 - 85 % (non-condensation)	
18. Surface Treatment	Zinc Plating, Trivalent chromate finish	
19. Teach Pendant	TFT color display (5.7 inch LCD) with touch panel Emergency Stop SW, Teach Lock SW and Enable SW	
20. Safety Circuit	Category: 3, Performance Level: d (EN ISO13849-1: 2008) ★	
21. Options		
General purpose signals	Input signals	64/96 channels
	Output signals	64/96 channels
I/O connector	D-SUB 37pin(male,female) with cover	
Operation panel	Motor Power ON, Cycle start, RUN/HOLD, Error reset, Error lamp	
Power/Signal cable	5m, 15m	
Teach Pendant cable	5m, 15m	
Motor brake release	Manual brake release switch BOX	
Auxiliary storage	USB memory	
PC cable	1.5 m, 3 m	
Teach Pendant option	Connector for TP less	
Others	Field BUS, Software PLC, Analog input/output, Conveyor Synchronization, Vision and so on	
22. Others	Consult Kawasaki about maintenance parts and spare parts.	

★ Category and Performance level (PL) are determined by the whole system and conditions. □
The safety circuit of this controller is available in the system of category: up to 3, PL: up to d.

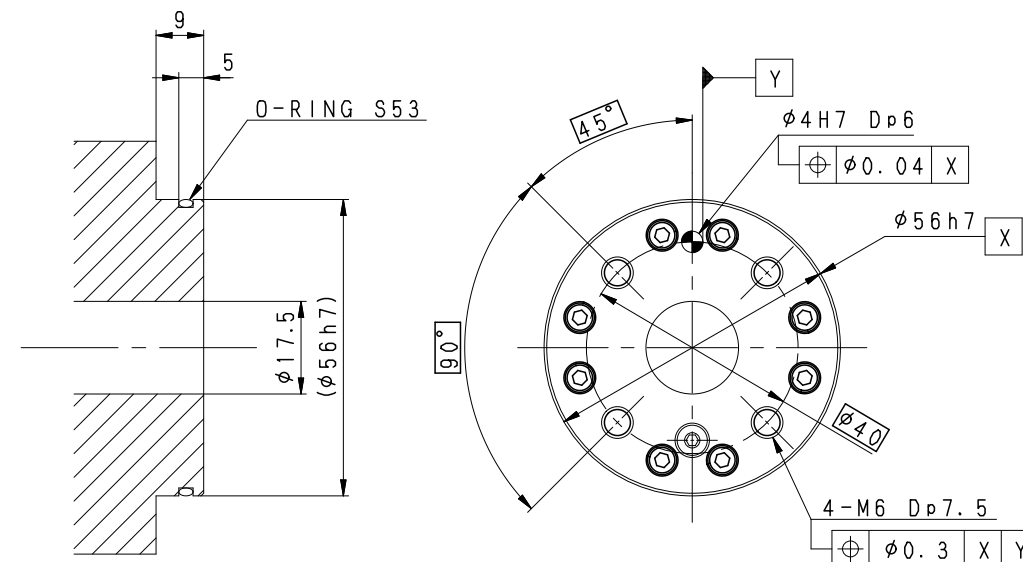
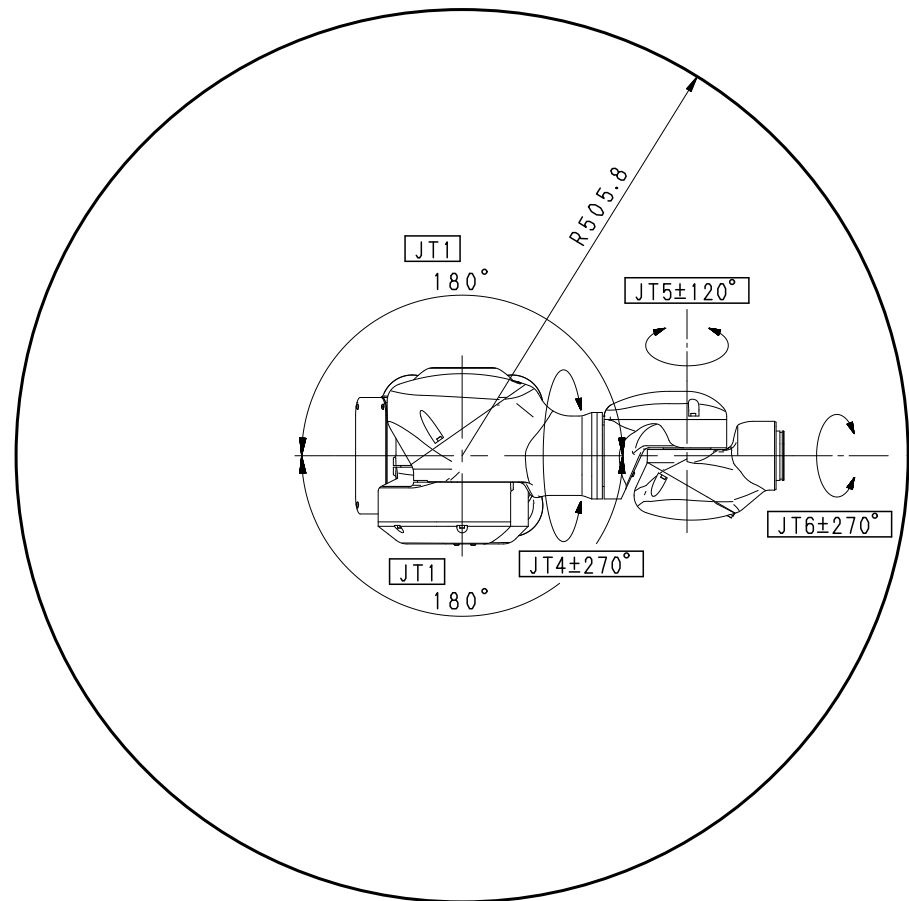

VIEW B

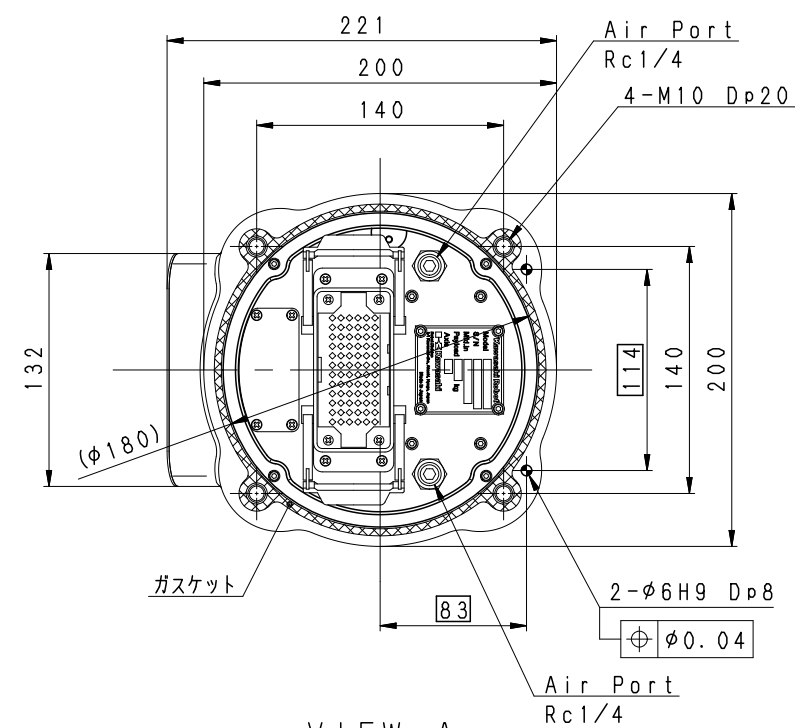
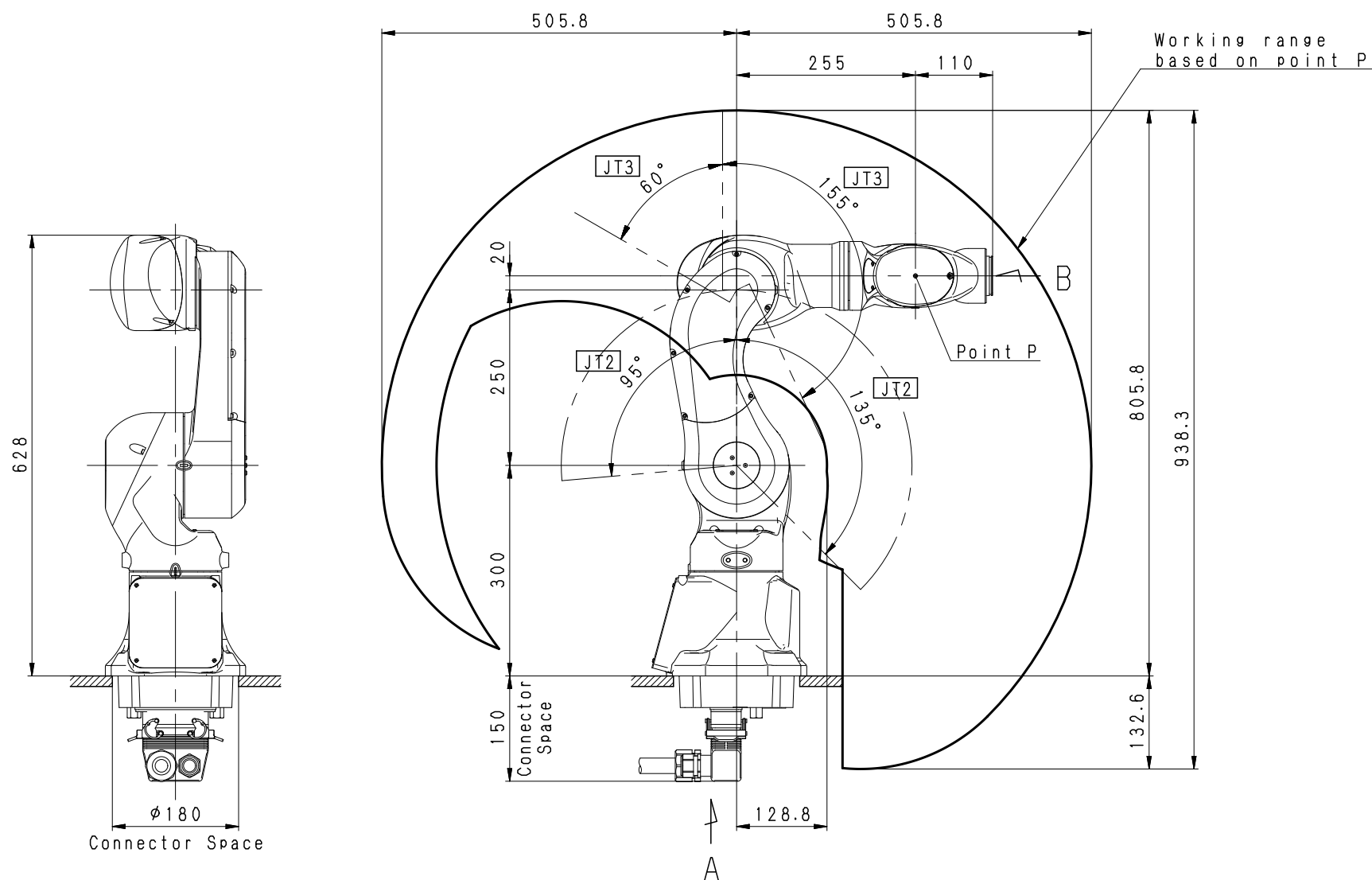

VIEW A
(Installation Dimensions)

MCR04N
WORKING RANGE

E 7 0 / E 7 1 C O N T R O L L E R

M A S S : 3 0 K g

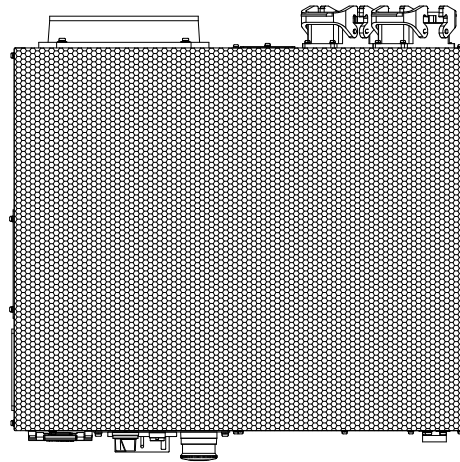
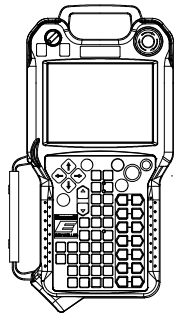

T O P V I E W

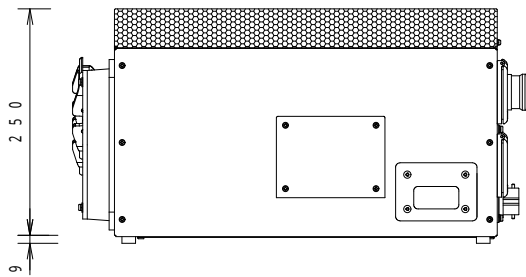
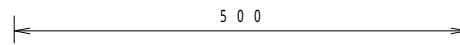
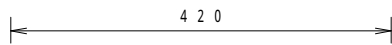

S I D E V I E W

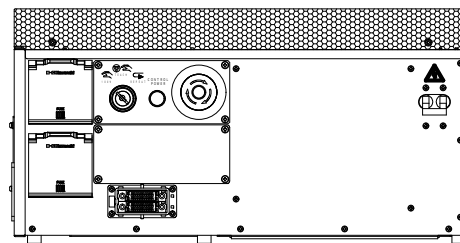

F R O N T V I E W

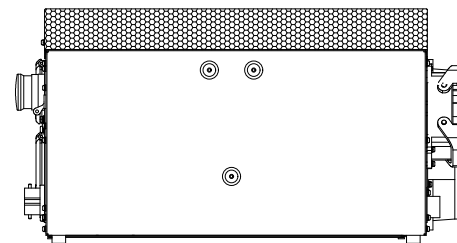

S I D E V I E W

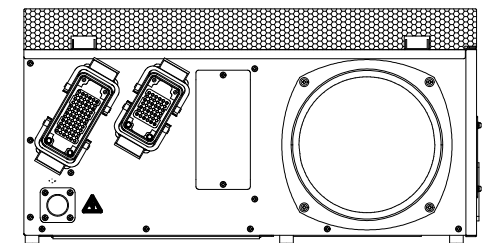

R E A R V I E W